



ZERO COGGING | OPTIMIZED FOR POWER DENSITY | LIGHT-WEIGHT AND LARGE APERTURE
HIGHLY EFFICIENT ARCHITECTURE | IRONLESS COMPOSITE STATOR | SCALABLE SIZE AND POWER

Data Sheet Model Number: **TG 231X-XX**

ThinGap's TG Series includes numerous high performance brushless permanent magnet motors. The TG Series targets higher speed, high-precision applications such as where a smooth motion and weight optimized solution is desired.

Model Number Nomenclature	TG 23 1 X -XX
Motor Series	TG 23
Rotor Configuration	1
Winding Configuration (0-WYE)	X
Mounting Option (M1/M2-Framed, P1- Frameless Part Set)	-XX
Example	TG 2311-M1

Winding Independent Parameter Table **TG 231X**

Performance Parameters	Units	Value
Continuous Torque @ Max Speed	N-m	0.74
Max Continuous Speed	RPM	6500
Max Continuous Power	W	500
Peak Parameters @ Max Speed	Units	Value
Peak Torque (1 sec)	N-m	2.68
Peak Torque (3 sec)	N-m	1.61
Mechanical Parameters	Units	Value
Rotor Inertia	kg-m ²	1.90E-04
Number of Magnetic Poles	ea	8
Outer Diameter	mm	57
Through Hole Diameter	mm	33
Axial Height	mm	62
Part Set Mass (Rotor and Stator)	kg	0.449
Total Motor Mass M1	kg	0.611
Total Motor Mass M2	kg	0.634
Temperature Parameters	Units	Value
Max Stator Temperature	°C	100

Winding dependent Parameter Table **TG 2310**

Electrical Parameters	Units	Value
Winding Configuration		WYE
Required Motor Voltage @ Max Speed	V _{pk-l}	41.5
Max Continuous Phase Current @ Max Speed *	A _{RMS}	11.6
Voltage Constant (I-I)	V _{pk-l} /rad/s	0.056
Voltage Constant (I-I)	V _{pk-l} /kRPM	5.8
Torque Constant	N-m/A _{RMS}	0.068
Motor Constant	N-m/√W	0.1
Terminal Resistance	Ω	0.31
Terminal Inductance	μH	20.6

* Current value takes into account temperature losses during operation.



ThinGap's TG Line of Brushless motors designed for high speed, high power power applications such as propulsion, reaction wheels, and precisions industrial. These motor kits are available in sizes ranging from 57mm to 190 mm

Torque and Mechanical Speed

Continuous rated torque of up to 0.74 N-m and a rated speed of up to 6500 RPM.

Motor Controller Recommendation

Standard 3-Phase Controller
High Frequency PWM power input

Resources for Integration

CAD files at: www.thingap.com

Complete Mechanical drawings available upon request



thin gap

TG SERIES
MOTOR KIT

TG 231X-XX

TG 231X-XX Mechanical Information

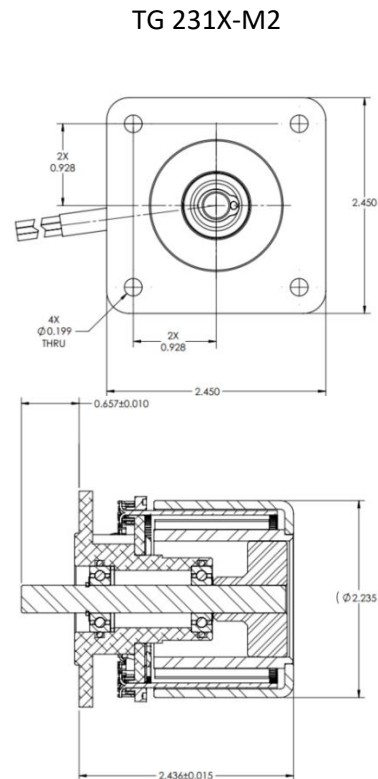
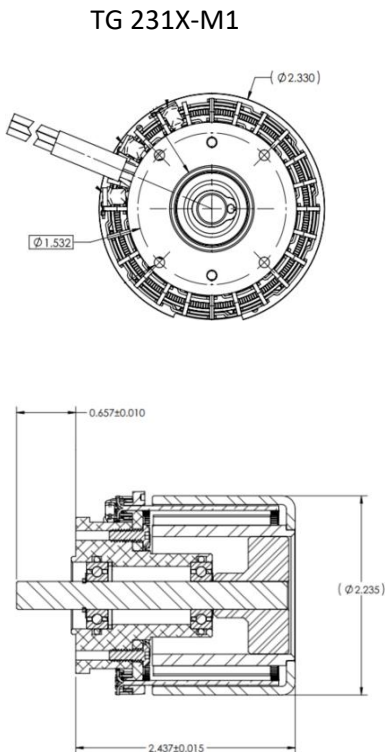
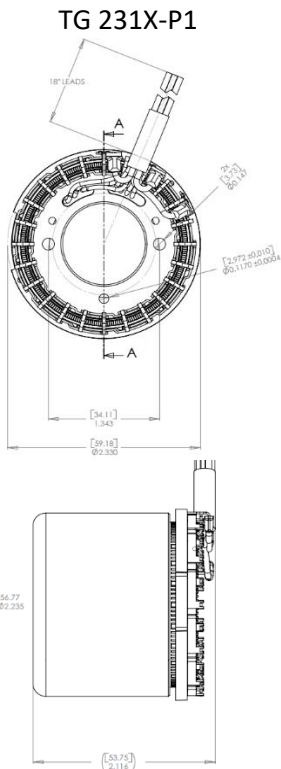

General Mechanical Specifications

All values should be considered nominal. Please consult factory for up-to-date mechanical drawing and ICD.

TG Series Options and Motor Capabilities

Basic Kit Sizes Available:				
TG Sub-Series	Motor Model	OD (inch/mm)	Con.Torque (N-m)	Max Speed (RPM)
2 Series (2" OD)	TGI 231X	2.2 / 57	0.74	6,500
	TGO 232X	2.2 / 57	0.35	16,000
	TGO 233X	2.2 / 57	0.69	16,000
	TGD 234X	2.2 / 57	1.02	6,500
	TGI 046	1.8 / 46	0.71	3,300
3 Series (3" OD)	TG 303X	2.8 / 71	0.14	30,600
	TG 304X	2.9 / 75	0.19	28,400
	TG 305X	3.0 / 76	0.21	17,900
4 Series (4" OD)	TGO 110	4.3 / 110	0.99	4,000
5 Series (5" OD)	TG 513X	5.2 / 131	1.68	18,400
	TG 514X	5.4 / 136	2.65	13,900
	TG 515X	5.5 / 138	3.57	10,300
7 Series (7" OD)	TG 713X	7.0 / 178	2.98	13,700
	TG 714X	7.2 / 182	4.26	10,800
	TG 715X	7.5 / 190	4.83	10,300
	TGO 190	7.5 / 190	9.46	6000

REGION OF OPERATION

